

Bombas de Mezcla

QY-Series Liquid Gas Mixing Pump Specifications

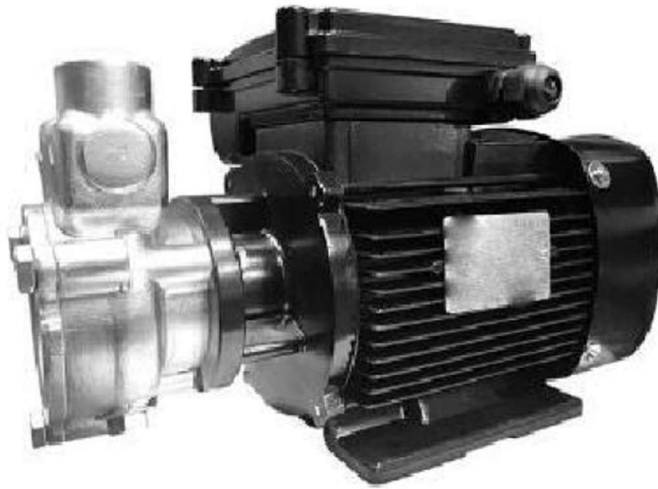

ozone water mixing pump, gas liquid mixing pump, water pump

Mixing system for ozone dissolved in water

1. Mixing system is simple and it intakes Ozone gas to the pump and mix Ozone with liquid in the pump, while conventional system needs additional equipment like "ejector" and "static mixer" to make ozone water.
2. Ozone dissolution ratio is more than 80~100% in case of out mixing system which is extremely high compared with conventional system. This dissolution ratio varies depending on water temperature, gas concentration, PH concentration etc.
3. CH Mixng pump is most suitable to pressurize the air and liquid, and let the air dissolved into the liquid, compared with any other type of pumps and apparatus like atatic mixer.
4. CH system does not use compressor, pressure dissolve tank, ejector and static mixer, which makes our system small in size and competitive in price. In case of conventional centrifugal pump method, the pump suck the liquid and air, and mix them and transport them.

Item	20QY-1	25QY-2SS	40QY-6SS	50QY-12
Head of delivery (m)	40		50	
Flow rate (M3/Hr)	0.4~2.8	1~3.5	3.5~8	7.5~18
Water input size (Inch)	0.75"	1"	1.5"	2"
Water output size (Inch)	0.5"	0.75"	1.2"	1.5"
Power (Kw)	0.55	1.1	3	5.5
Phase	Single phase	Single phase	Three phase	Three phase
Voltage	220V/50Hz	220V/50Hz	380V/50Hz	380V/50Hz
	110V/ 60Hz		380V/60hz	
Speed (r/min)	2900			

Installation drawing

