

LFC-1000

Bio-Digester



Reduce Carbon Footprint

Safely digests 1000–1800 kg (2200–4000 lbs) of waste food per day

Add waste food anytime

Quickly digests waste food with no odor or noise

Automatic Bin Lift

Easily lifts 150 litre (40 gallon) bin



The LFC-1000 is a fully enclosed automatic bio-digester that safely disposes of 1000–18000 kg (2200–4000 lbs) of waste food each 24 hours with no noise or odor. Once installed, you can use the bin lift to add waste at any time without needing to empty byproducts. The LFC discharges only decomposed food as grey water that is environmentally safe.

With our proprietary mixture of microbes and enzymes, the LFC uses a series of processes in which microorganisms break down biodegradable material in the presence of oxygen. The LFC maintains equilibrium for the microorganisms

by injecting water periodically; this rapidly decomposes the waste food and flushes decomposed material out of the LFC.

Every 20 minutes, the LFC rotates an arm inside to slowly mix new waste food, old waste food, oxygen, water, and microorganisms to enhance the decomposition.

The LFC is a practical alternative to the traditional disposal of waste food. Anything you can eat, including fruits, vegetables, meat, fish, cheese, bread, rice, and noodles can go into the LFC.

LFC-1000

Technical Specifications

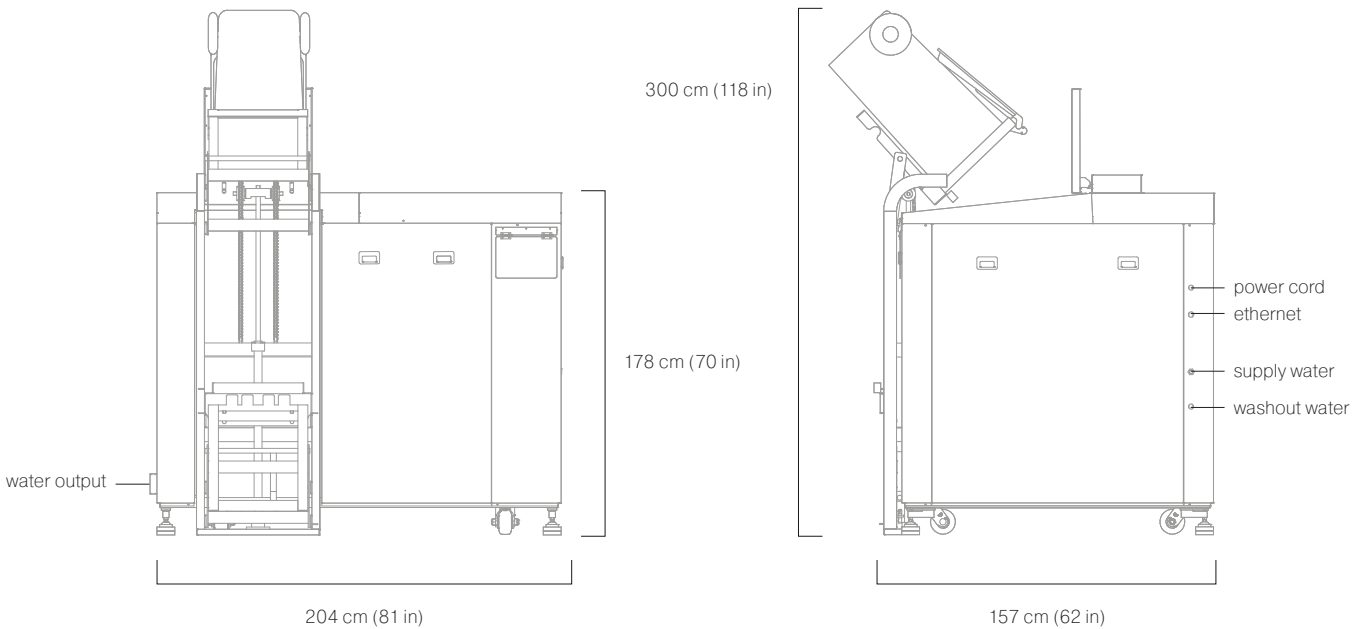

Capacity per Day

1000–18000 kg (2200–4000 lbs)

Construction

All stainless steel (chassis, side panels, drum, shaft, arms, paddle, and load cells)

Dimensions

204 x 157 x 178 cm (81 x 62 x 70 in)

Weight when Empty

1250 kg (27600 lbs)

Water Inlet

½" female (DN15), 250 to 700 kPa (36 to 100 psi, 2.5 to 7 kg/cm²)

Water per Day

1900 litres (500 gallons) typical

AC Supply

208 V, 60 Hz or 400 V, 50 Hz
15 A, 3-phase

Maximum Power

4.5 kW

Energy per Day

24 kWh typical

Weighing Accuracy

±1%

User Interface

22 mm 3-color LED
4" touchscreen with 65k colors

Ethernet

RJ45, 100 baseT, DHCP
or fixed IP address

Operating Environment

Indoors or covered patio

Operating Temperature

4°C to 35°C (39°F to 95°F)

Ingress Protection

IP54 – splash proof and dust proof

Powerzyme

1 litre, included with initial purchase

Powerchips

100 litre, included with initial purchase

Operating Lifetime

Expected to be 15 to 25 years

Warranty

3 years on all parts and components

Safety

Certified to UL430
(waste disposal machines)
CAN/CSA-C22.2 No. 60335-1:11
EN 60335-1:2010+AMD1:2013
(general safety)
CAN/CSA-C22.2 No. 60335-2-16:16
EN 60335-2-16:2002+A1:2008+A2:2011
(waste food disposers)

EMC

EN 61000-6-3:2007+A1:2011
EN 61000-6-1:2007
EN 61000-3-2:2006+A1:2008+A2:2009
EN 61000-3-3:2013

RoHS

Compliant for EU and China



Power Knot LLC | 2290 Ringwood Avenue | San Jose, CA 95131 USA | +1-408-889-8433 | info@powerknot.com | www.powerknot.com

Power Knot, the Power Knot logo, the Power Knot mark, LFC, and LFC Cloud are trademarks or registered trademarks of Power Knot LLC. All other trademarks used herein are the property of their respective owners. Copyright © 2009–2017 Power Knot LLC; all rights are reserved. Specifications are subject to change at any time without notice. Document number 96-01040-01, 21 February 2017.